

# ERG series

## High Precision Rotary Type

### ■ Innovation patented invention:

1. Innovation surface grinding machine controller: Patent No.:1546161
2. Innovation equal feeding speed control: Patent No.:M454893
3. Innovation rotary & square constitute design: Patent No.:1508818 & M454892
4. Innovation multi-sound alarm light structure: Patent No.: M486838

[www.equiptop.com.tw](http://www.equiptop.com.tw)

EXCELLENT · FEATURES · PROVIDE · VALUE



# EQUIPTOP HISTORY

**Experienced Managing Team / Brilliant Quality Policy / Marketing Management / Complete Product Series / Fast Service / Innovative R & D Idea.**

- 1988 Established " EQUIPTOP MACHINERY CO., LTD" Made a speciality of developing high precision surface grinders.
- 1990 Developed ESG-618 & 818 ASD series, 3 axis fully automatic surface grinders. Used PC-CAD to upgrade mechanical design and development.
- 1992 Developed ESG-1228 & 1236 ASD series, 3 axis fully automatic surface grinders.
- 1993 Developed ESG-1632 & 1640 ASD series, 3 axis fully automatic surface grinders.
- 1995 Developed ESG-1020 & 1224 ASD series, 3 axis fully automatic surface grinders. Obtained CE-Mark certificate from AMTRI CE in England.
- 1997 Developed ESG-2448 to 2480, 3axis fully automatic, digital positioning ADX series, with a downfeed jog movement providing just 0.5 μm super microfeed for finer production finish.  
Column type surface grinder, using high anti-wear, heavy duty preloaded, H class linear guideway.
- 1998 Awarded ISO 9002 Certification by DNV company of Netherlands.
- 1999 Invested in "NANJING EQUIPTOP PRECISION MACHINERY CO., LTD." as branch in China.
- 2000 Developed ESG-3260 to 32120, 3axis fully automatic, smart digital positioning ADX series.  
Reveived certified CE-MARK by DNV company.
- 2001 Awarded Certified ISO 9000 by Bell company.  
Developed NC series, 3 axis fully automatic smart digital positioning grinders.
- 2002 Grand Opening of a new factory. The new facility is over 13,000m<sup>2</sup>.  
Invested 1.6 hundred million dollars in this new headquarters.  
Successfully developed new complex grinders, moving EQUIPTOP into the high technology area.  
Renamed the company as "EQUIPTOP HITECH CORP."
- 2003 Awarded publication 2000 ISO 9001 certification. Developed " ASD II " series, 3 axis, fully automatic digital positioning grinders. Developed " ACUMEM " super microfeed servo control and auto-wheel dressing & compensation system grinders.
- 2004 Established the branch in Wu Hsi-Shuai Hung Precision Machinery LTD. to expand China market.  
Developed cantilever type ESG-6120~8300 ASD II series, 3 axis, fully automatic surface grinders.
- 2005 Obtained the prize of Taiwan Precision Product in manufacturing NC surface profile grinder.
- 2006 Developed ETM510APC tapping machine with auto pallet changer system & Double column grinding machine, table size 1500x3000~1500x5000 are available.
- 2008 Double column grinding machine, table size 1500x3000~1500x5000 are available.
- 2010 Upgrade ASD II series to TD type. PLC control & touch color screen.
- 2012 Double column type grinding machine, table size 1200x3000~1200x5000 are available. Developed ESG-2448 to 24120, 3axis fully automatic TD type with touch color screen.
- 2013 Execute rotary & square constitute, hydrostatic spindle and guide rail program. Presented EMV-600APC auto pallet change, and 800 x2000~5000mm, 1000x2000~5000 mm double column grinders.
- 2016 Innovation patented invention:  
1. Innovation surface grinding machine controller: Patent No.:1546161  
2. Innovation equal feeding speed control: Patent No.:M454893  
3. Innovation rotary & square constitute design: Patent No.:1508818 & M454892  
4. Innovation multi-sound alarm light structure: Patent No.: M486838

## Patent Items

### Obtained national patents for grinder:

- Longitudinal straight movement construction of surface grinder.
- Timing belt straight drive system.
- Dual motors, positioning and feeding structure.

### More national patents:

- Timing belt drive system for the table of surface grinders.
- Roughing and micro table speed control construction.
- New travel direction change for surface grinding.

### Obtained US patents:

- Surface grinding table reverse construction.
- Belt drive construction for surface grinding table.

### Obtain German patent:

- Safety handwheel system.

### Honored with national patents:

- Multi-formed grinder.
- Dust collect / coolant and dust unit.

- NC & CNC multiple formed molds.
- One wire of table multiple transmission.
- Motor fan cooling structure.
- Simultaneous processor.
- Vacuum wind turbine structure for dust coolant.
- Improvement to dust coolant structure.
- Rotary square structure.
- Equal speed.
- New type double column complex spindle head.
- Milling grinding complex spindle head.



# Innovative Rotary & Square Constitute • Equal Feeding Speed Technology

**FFG EQUIPTOP**  
EQUIPTOP HI TECH CORP.  
www.equip-top.com.tw

"EQUIPTOP" means "TOP EQUIPMENT"  
A Wise Choice-Equip-top.

Working coordinates		DISTANCE TO GO		Mechanical coordinates	
Y	000.000	Y	000.000	Y	000.000
Z	000.000	Z	000.000	Z	000.000

Surface grinding	Start Point	Finish Volume	Target Point	Rise Up Point	Z1 start point	Z2 stop point
Manual	0.000	0.000	0.000	0.000	0.000	0.000

### Machine I/O surveillance mode

Standard: Input, Output

Functions: Y-Axis Servo, Z-Axis Servo, B-Axis Servo, Peripheral I/O, Scan points

### Machine I/O surveillance

- X0.0 Y-axis encoder A signal
- X0.1 Y-axis encoder B signal
- X0.2 Z-axis encoder A signal
- X0.3 Z-axis encoder B signal
- X0.4 B-axis encoder A signal
- X0.5 B-axis encoder B signal
- X0.6 Z axis limited switch
- X0.7 Reserved
- X0.8 Y-axis encoder Z signal
- X0.9 Z-axis encoder Z signal
- X0.10 MPG Handle A signal
- X0.11 MPG Handle B signal
- X0.12 Y axis HOME signal
- X0.13 Z axis HOME signal
- X0.14 Y upper limited switch
- X0.15 hydrostatic cooling system OK

### Mechanical parameter setting

Y Axis, Spindle, Z Axis, LUBE, B Axis, Other, Set Password, System time, date, Adjust Contrast Brightness

### Y axis parameter setting

Y axis Max. speed (pre-set 120mm/min)	0
AUTO mode, Y downfeed delay time (pre-set 0 sec)	0.0
AUTO mode, over the rise up point to eliminate backlash	0
AUTO mode, rise up speed	0
AUTO mode, rise up speed	0.000
	0
	0
	0
	0
	0

### Functional menu

- Wheel information
- Wheel RPM list
- Multi-Machine central Monitoring
- Machine Service Process
- Server abnormal code
- Precautions
- Electrical System
- Maintenance Inspection

### New sales service process

Global machine users, Machine users, Alarm message transmission, Alarm message analysis

### Traditional sales service process

USER, LOCAL DISTRIBUTOR, SERVICE AND TEST IN USER FACTORY, SERVICE TIME: 1-2 DAY, SERVICE CONFIRM: 3-7 DAY

### Multi-machine monitor

Multi-machine monitor, APP, Please check the alarm messages immediately.



# ERG FEATURES

- Innovative equal feeding speed technology, auto variable speed change according to process position. Low power required for economy and energy conservation.
- Conformed to intuition operation mode to decrease setting mistake and easy to monitor the process condition.
- Auto compensation according wheel dressing time, speed and wheel dressing value. Precision reaches 100nm.
- The controller calculates the setting and offer best program for process efficiency.
- The setting value can be adjusted during process. No need to stop the machine.
- Monitoring and process in the same time, immediately feedback for problem solve.
- Fast value input for working. It can saving the program time.
- Innovation patented invention:
  1. Innovation surface grinding machine controller: Patent No.:1546161
  2. Innovation equal feeding speed control: Patent No.:M454893
  3. Innovation rotary & square constitute design: Patent No.:1508818 & M454892
  4. Innovation multi-sound alarm light structure: Patent No.: M486838

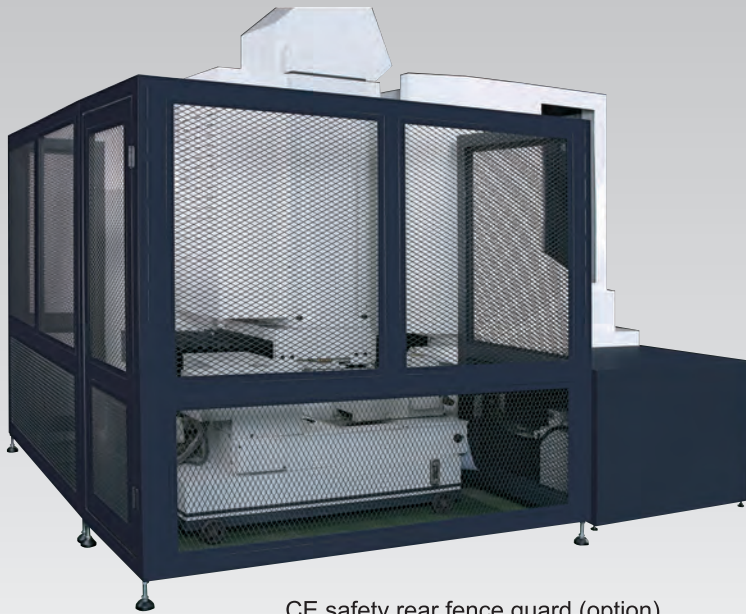

CE safety rear fence guard (option)



Y axis servo direct drive transmission mechanism, collocated with super precision SP class linear guide way. (High rigidity roller type linear way is available as option.)

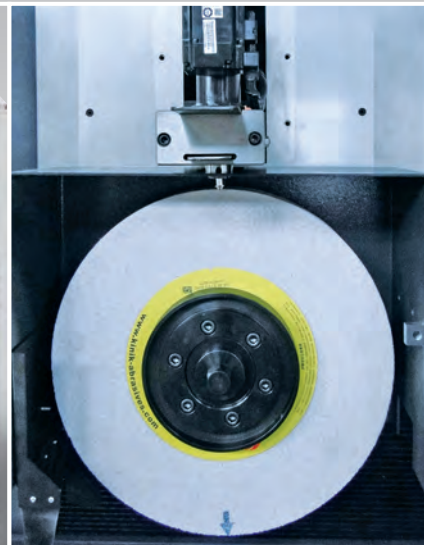

Applied with controller, the wheel auto compensation value reaches high accuracy of 100nm (0.0001mm). (Wheel head servo dressing & compensation mechanism is optional)

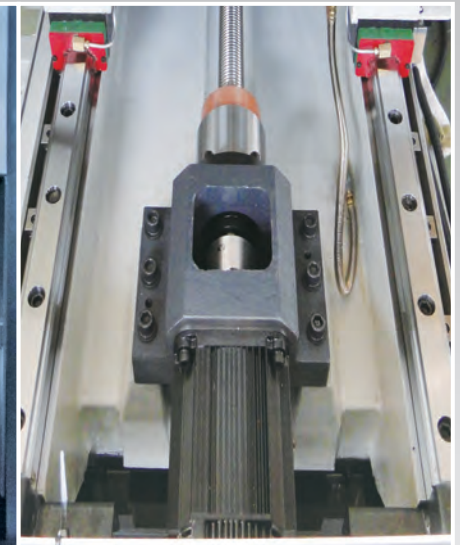

Equipped with reliable direct drive transmission mechanism, collocated with excellent clever movement and super precision SP class linear rail. (High rigidity roller type linear way is available as option.)

*Direct drive • SP class linear guide way • High rigidity linear type guide way*

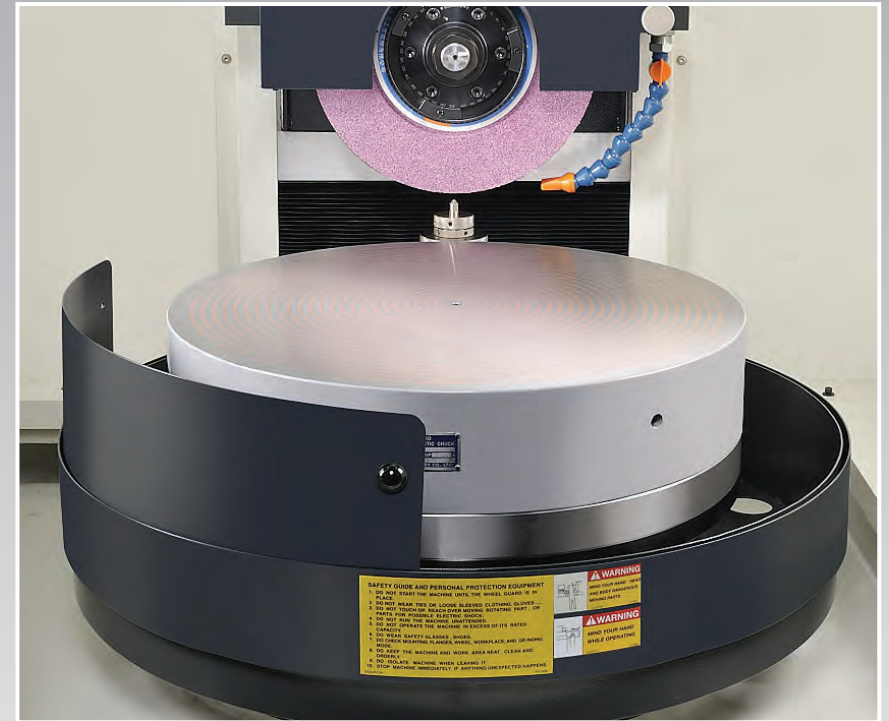

- Innovation equal feeding speed control: Patent No.:M454893
- The hydrostatic rotary table, use the oil as a medium to reduce the wear on the structure, reducing the machining error caused by traditional rotary table ball bearing design, rise up and improve processing accuracy and stability, also can get more higher carry capacity and machine life.



**ERG-500**

ERG-500

**ERG-600**

ERG-600

**ERG-800**

ERG-800

**ERG-1000**

ERG-1000



*ERG-500 / ERG-600 / ERG-800 / ERG-1000 Hydrostatic high precision horizontal type grinder*

# Machine structure deform analysis • Rotary & square constitute analysis

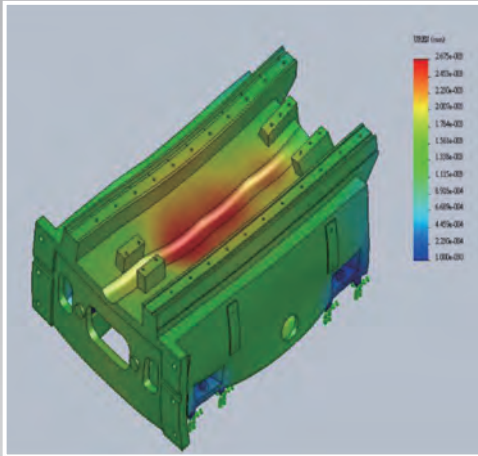

Base displacement analysis

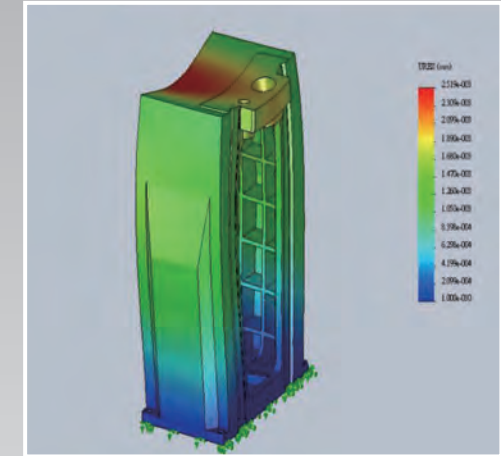
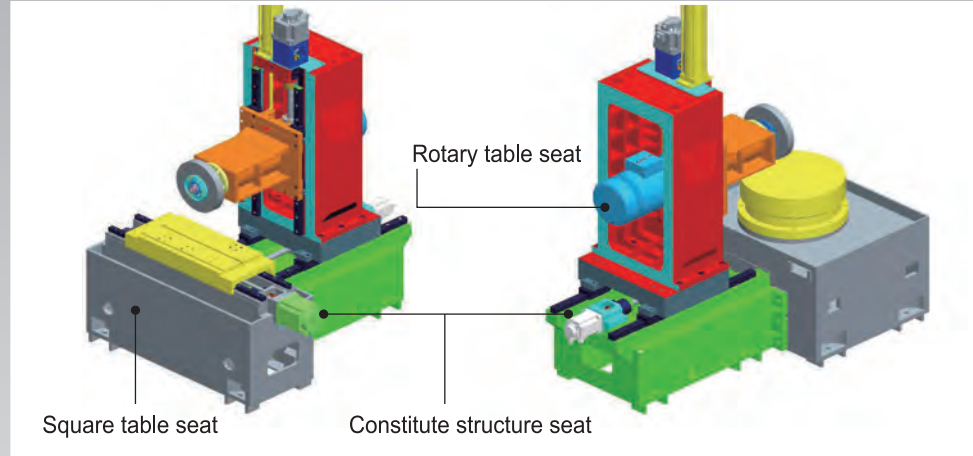

Column displacement analysis

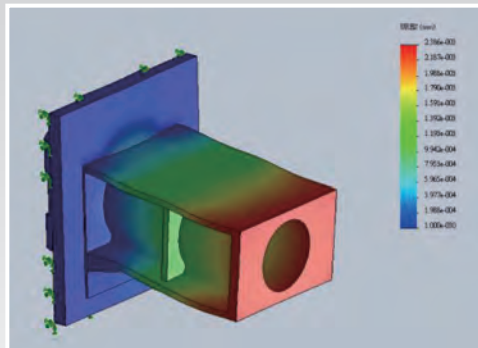

Spindle seat displacement analysis

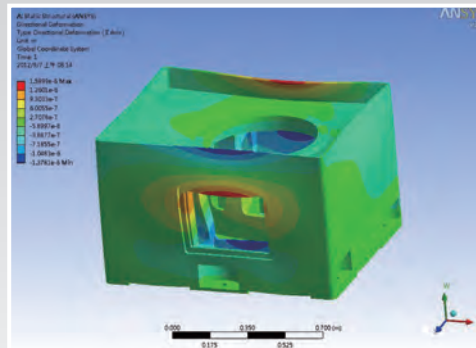

Seat analysis result (Z direction deformed)

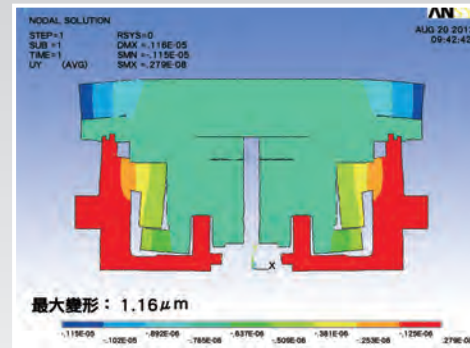

Rotary table analysis result (Y direction deformed)

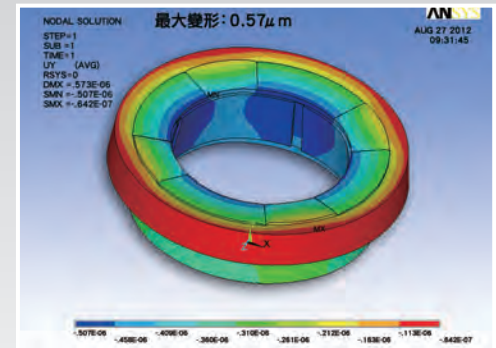

Direction deformed Y rotary table guide way (Rotary table analysis result)



# ERG - 500B TD Plus / 600B TD Plus



*B Type: Bearing Type high precision grinder*

# *ERG / ERG B Type Series Specification*

ITEM		UNIT	ERG-500	ERG-600	ERG-800	ERG-1000	ERG-500B	ERG-600B	
Rotary table structure	Rotary table Dia.	mm	Ø500	Ø600	Ø800	Ø1000	Ø500	Ø600	
	Max. grinding radius	mm	Ø500	Ø600	Ø800	Ø1000	Ø500	Ø600	
	Rotary speed	Max. speed	rpm	250		50	40	180	
		Min. speed	rpm	10					
		Infinitely variable		10-250		10-50	10-40	10~180	
	Max. load	kg	600	800	1000	1300	600	800	
	Spindle center to table surface	mm	640 (chuck is excluded)						
Standard rotary electro chuck		mm	Ø500x110	Ø600x115	Ø800x120	Ø1000x120	Ø500x110	Ø600x115	
Z axis cross movement	Constant feed	mm/min	20~600						
	Auto Max. travel (mm)	mm	540			640	540		
	Manual Max. travel (mm)	mm	545			645	545		
	MPG Per Graduation (mm)	mm	0.001x1 / x10						
Y axis vertical feed	Auto feed volume (mm)	mm	0.001-0.05						
	MPG Per Graduation (mm)	mm	0.001x1 / x10						
	Rapid up/down	mm/min	400						
	Slow up/down	mm/min	6						
	Spindle speed	rpm	50 / 60HZ, 1450 / 1750						
Motor	Spindle motor	kw	7.5 (option 11)						
	Rotary table motor	kw	3						
	Y axis motor	kw	1						
	Z axis motor	kw	1.5						
Grind wheel	O.D. x W x Core	mm	355 x 50 x 127						
Hydraulic drive	Rotary type table	kw / L	0.75 / 75						
Floor space	Space needed(LxWxH)	mm	3600 x 3600 x 2600			3750 x 3600 x 2600		3600 x 3000 x 2600	
	Weight	kg	4300	4500	4700	5300	4000	4200	
	Total rated power (Approx.)	HP	23			25		20	





# EQUIPTOP®



*"EQUIPTOP" means "TOP EQUIPMENT" A Wise Choice-Equiptop.*



**EQUIPTOP HITECH CORP.** NO. 88, SAN FENG E. RD., HOULI DISTRICT,  
TAICHUNG CITY, TAIWAN 42156

■ TEL: +886-4-25576060

■ FAX: +886-4-25569677.25575866

■ e-mail: [equiptop@hibox.hinet.net](mailto:equiptop@hibox.hinet.net)

■ <http://www.equiptop.com.tw>

*[www.equiptop.com.tw](http://www.equiptop.com.tw)*